

European Technical Approval ETA-12/0471

English translation prepared by DIBt - Original version in German language

Handelsbezeichnung
Trade name

BM Quick Drill, BM Quick Drill +, BM Quick Drill II, BM Quick Drill III, BM
DT Quick Drill und BM FT Quick Drill Schrauben
*BM Quick Drill, BM Quick Drill +, BM Quick Drill II, BM Quick Drill III, BM
DT Quick Drill and BM FT Quick Drill screws*

Zulassungsinhaber
Holder of approval

Bi-Mirth Corporation
No. 3, Alley 7, Lane 96, Ping Der Road
TAI-CHUNG
TAIWAN R.O.C

Zulassungsgegenstand
und Verwendungszweck
*Generic type and use
of construction product*

BM Quick Drill Schrauben als Holzverbindungsmittel
BM Quick Drill screws for use in timber constructions

Geltungsdauer:
Validity: vom
from
bis
to

13 June 2013
8 January 2018

Herstellwerke
Manufacturing plants

Werk 1
Plant 1

Diese Zulassung umfasst
This Approval contains

27 Seiten einschließlich 4 Anhänge
27 pages including 4 annexes

Diese Zulassung ersetzt
This Approval replaces

ETA-12/0471 mit Geltungsdauer vom 08.01.2013 bis 08.01.2018
ETA-12/0471 with validity from 08.01.2013 to 08.01.2018

I LEGAL BASES AND GENERAL CONDITIONS

- 1 This European technical approval is issued by Deutsches Institut für Bautechnik in accordance with:
 - Council Directive 89/106/EEC of 21 December 1988 on the approximation of laws, regulations and administrative provisions of Member States relating to construction products¹, modified by Council Directive 93/68/EEC² and Regulation (EC) N° 1882/2003 of the European Parliament and of the Council³;
 - *Gesetz über das In-Verkehr-Bringen von und den freien Warenverkehr mit Bauprodukten zur Umsetzung der Richtlinie 89/106/EWG des Rates vom 21. Dezember 1988 zur Angleichung der Rechts- und Verwaltungsvorschriften der Mitgliedstaaten über Bauprodukte und anderer Rechtsakte der Europäischen Gemeinschaften (Bauproduktengesetz - BauPG) vom 28. April 1998⁴, as amended by Article 2 of the law of 8 November 2011⁵;*
 - Common Procedural Rules for Requesting, Preparing and the Granting of European technical approvals set out in the Annex to Commission Decision 94/23/EC⁶.
- 2 Deutsches Institut für Bautechnik is authorized to check whether the provisions of this European technical approval are met. Checking may take place in the manufacturing plant. Nevertheless, the responsibility for the conformity of the products to the European technical approval and for their fitness for the intended use remains with the holder of the European technical approval.
- 3 This European technical approval is not to be transferred to manufacturers or agents of manufacturers other than those indicated on page 1, or manufacturing plants other than those indicated on page 1 of this European technical approval.
- 4 This European technical approval may be withdrawn by Deutsches Institut für Bautechnik, in particular pursuant to information by the Commission according to Article 5(1) of Council Directive 89/106/EEC.
- 5 Reproduction of this European technical approval including transmission by electronic means shall be in full. However, partial reproduction can be made with the written consent of Deutsches Institut für Bautechnik. In this case partial reproduction has to be designated as such. Texts and drawings of advertising brochures shall not contradict or misuse the European technical approval.
- 6 The European technical approval is issued by the approval body in its official language. This version corresponds fully to the version circulated within EOTA. Translations into other languages have to be designated as such.

¹ Official Journal of the European Communities L 40, 11 February 1989, p. 12
² Official Journal of the European Communities L 220, 30 August 1993, p. 1
³ Official Journal of the European Union L 284, 31 October 2003, p. 25
⁴ *Bundesgesetzblatt Teil I 1998*, p. 812
⁵ *Bundesgesetzblatt Teil I 2011*, p. 2178
⁶ Official Journal of the European Communities L 17, 20 January 1994, p. 34

II SPECIFIC CONDITIONS OF THE EUROPEAN TECHNICAL APPROVAL

1 Definition of product and intended use

1.1 Definition of the construction product

BM Quick Drill, BM Quick Drill +, BM Quick Drill II, BM Quick Drill III, BM DT Quick Drill and BM FT Quick Drill screws are self-tapping screws made from special carbon steel. The screws are hardened. The screws have a corrosion protection according to Annex A 1.6 and an antifriction coating. The outer thread diameter is not less than 6.0 mm and not greater than 14.0 mm. The overall length of the screws is ranging from 40 mm to 1500 mm. Further dimensions are shown in Annex 4.

The washers are made from carbon steel. The dimensions of the washers are given in Annex 4.

1.2 Intended use

The screws are intended to be used for connecting wood-based members, where requirements for mechanical resistance and stability and safety in use in the sense of the essential requirements N 1 and N 4 of Council Directive 89/106/EEC shall be fulfilled.

The screws are used for connections in load bearing timber structures between wood-based members or between those members and steel members:

- Solid timber (softwood) of strength classes C14 – C40 according to EN 338⁷/ EN 14081-1⁸,
- Glued laminated timber (softwood) of at least strength class GL24c according to EN 1194⁹/ EN 14080¹⁰,
- Laminated veneer lumber LVL according to EN 14374¹¹, arrangement of the screws only perpendicular to the plane of the veneers
- Glued laminated solid timber Duo- and Triobalken according to FprEN 14080¹² or national provisions that apply at the installation site
- Cross-laminated timber according to European technical approvals or national provisions that apply at the installation site

The screws may be used for connecting the following wood-based panels to the timber members mentioned above:

- Plywood according to EN 636¹³ and EN 13986¹⁴,
- Oriented Strand Board, OSB according to EN 300¹⁵ and EN 13986,
- Particleboard according to EN 312¹⁶ and EN 13986,

7	EN 338:2009	Timber structures - Strength classes
8	EN 14081-1:2005+A1:2011	Timber structures – Strength graded structural timber with rectangular cross section – Part 1: General requirements
9	EN 1194:1999	Timber structures – Glued laminated timber – Strength classes and determination of characteristic values
10	EN 14080:2005	Timber structures - Glued laminated timber - Requirements
11	EN 14374:2004	Timber structures - Structural laminated veneer lumber - Requirements
12	FprEN 14080:2013	Timber structures – Glued laminated timber and Glued laminated solid timber - Requirements
13	EN 636:2003	Plywood - Specifications
14	EN 13986:2004	Wood-based panels for use in construction - Characteristics, evaluation of conformity and marking
15	EN 300:2006	Oriented strand boards (OSB) – Definition, classification and specifications
16	EN 312:2003	Particleboards - Specifications

- Fibreboards according to EN 622-2¹⁷, EN 622-3¹⁸ and EN 13986,
- Cement-bonded particle boards according to national provisions that apply at the building site,
- Solid-wood panels according to national provisions that apply at the building site.

Wood-based panels shall only be arranged on the side of the screw head.

BM Quick Drill, BM Quick Drill +, BM Quick Drill II, BM Quick Drill III, BM DT Quick Drill and BM FT Quick Drill screws may be used for the fixing of thermal insulation material on top of rafters or on wood-based members in vertical façades.

BM FT Quick Drill screws may be used for compression reinforcing of timber structures perpendicular to the grain.

The scope of the screws regarding resistance to corrosion shall be defined according to national provisions that apply at the installation site considering environmental conditions. Annex 1.6 contains the corrosion protection for BM Quick Drill, BM Quick Drill +, BM Quick Drill II, BM Quick Drill III, BM DT Quick Drill and BM FT Quick Drill screws.

The screws may be used for connections subject to static or quasi static loading.

The provisions made in this European technical approval are based on an assumed working life of the screws of 50 years, provided that the conditions laid down in section 4.2 for the installation are met. The indications given on the working life cannot be interpreted as a guarantee given by the producer, but are to be regarded only as a means for choosing the right products in relation to the expected economically reasonable working life of the works.

2 Characteristics of product

	Characteristic	Assessment of characteristic
2.1 Mechanical resistance and stability ^{*)}		
2.1.1	Dimensions	See Annex 4
2.1.2	Characteristic yield moment	See Annex 1
2.1.3	Characteristic withdrawal parameter	See Annex 1
2.1.4	Characteristic head pull-through parameter	See Annex 1
2.1.5	Characteristic tensile strength	See Annex 1
2.1.6	Characteristic yield strength	See Annex 1
2.1.7	Characteristic torsional strength	See Annex 1

¹⁷

EN 622-2:2004

Fibreboards – Specifications – Part 2: Requirements for hardboards

¹⁸

EN 622-3:2004

Fibreboards - Specifications - Part 3: Requirements for medium boards

	Characteristic	Assessment of characteristic
2.1.8	Insertion moment	See Annex 1
2.1.9	Spacing, end and edge distances of the screws and minimum thickness of the wood based material	See Annex 1
2.1.10	Slip modulus for mainly axially loaded screws	See Annex 1
2.2 Safety in case of fire		
2.2.1	Reaction to fire	Self-tapping screws are made of steel classified as Euroclass A1 in accordance with EC decision 96/603/EC, as amended by EC decision 2000/605/EC.
2.3 Hygiene, health and the environment		
2.3.1	Content and/or release of dangerous substances	The product does not contain cadmium. There is no risk that chrome VI - contained in the chromated carbon steel screws - will be released by consideration of all possible release scenarios.**)
2.4 Safety in use		
2.4.1	Dimensions	See Annex 4
2.4.2	Characteristic yield moment	See Annex 1
2.4.3	Characteristic withdrawal parameter	See Annex 1
2.4.4	Characteristic head pull-through parameter	See Annex 1
2.4.5	Characteristic tensile strength	See Annex 1
2.4.6	Characteristic yield strength	See Annex 1
2.4.7	Characteristic torsional strength	See Annex 1
2.4.8	Insertion moment	See Annex 1
2.4.9	Spacing, end and edge distances of the screws and minimum thickness of the wood based material	See Annex 1

**)

In accordance with <http://ec.europa.eu/enterprise/construction/cpd-ds/>. In addition to the specific clauses relating to dangerous substances contained in this European technical approval, there may be other requirements applicable to the products falling within its scope (e.g. transposed European legislation and national laws, regulations and administrative provisions). In order to meet the provisions of the EU Construction Products Directive, these requirements need also to be complied with, when and where they apply.

	Characteristic	Assessment of characteristic
2.4.10	Slip modulus for mainly axially loaded screws	See Annex 1
Protection against noise		Not relevant
Energy economy and heat retention		Not relevant
2.5 General aspects relating to fitness for use		
2.5.1	Durability against corrosion	See Annex 1
2.5.2	Serviceability	The assessment for mechanical resistance and stability as well as durability against corrosion covers this property.

2.1 Mechanical resistance and stability

Annexes 1 to 2 contain the load-carrying capacities for BM Quick Drill, BM Quick Drill +, BM Quick Drill II, BM Quick Drill III, BM DT Quick Drill and BM FT Quick Drill screws. The design and construction shall be carried out according to national provisions that apply at the installation site in line with the partial safety factor format, e.g. in accordance with EN 1995-1-1.

3 Evaluation and attestation of conformity and CE marking

3.1 System of attestation of conformity

According to the decision 97/638/EC of the European Commission¹⁹ the system 2+ of attestation of conformity applies.

This system of attestation of conformity is defined as follows:

System 2+: Declaration of conformity of the product by the manufacturer on the basis of:

- (a) Tasks for the manufacturer:
 - (1) initial type-testing of the product;
 - (2) factory production control;
 - (3) testing of samples taken at the factory in accordance with a prescribed test plan.
- (b) Tasks for the approved body:
 - (4) certification of factory production control on the basis of:
 - initial inspection of factory and of factory production control;
 - continuous surveillance, assessment and approval of factory production control.

Note: Approved bodies are also referred to as "notified bodies".

¹⁹ Official Journal of the European Communities L 268/36 of 19 September 1997

3.2 Responsibilities

3.2.1 Tasks for the manufacturer

3.2.1.1 Factory production control

The manufacturer shall exercise permanent internal control of production. All the elements, requirements and provisions adopted by the manufacturer shall be documented in a systematic manner in the form of written policies and procedures, including records of results performed. This production control system shall insure that the product is in conformity with this European technical approval.

The manufacturer may only use raw materials stated in the technical documentation of this European technical approval supplied with the relevant inspection documents as laid down in the control plan.

The factory production control shall be in accordance with the "control plan relating to the European technical approval ETA-12/0471 issued on 13 June 2013" which is part of the technical documentation of this European technical approval. The control plan is laid down in the context of the factory production control system operated by the manufacturer and deposited with Deutsches Institut für Bautechnik.²⁰

The incoming raw materials shall be subject to controls and tests by the manufacturer before acceptance. Check of materials, such as steel rods or wire, shall include control of the inspection documents presented by suppliers (comparison with nominal values) by verifying dimension and determining material properties, e.g. chemical composition, mechanical properties and corrosion protection.

The manufactured components shall be checked visually and for dimensions. The control plan includes details of the extent, nature and frequency of testing and controls to be performed within the factory production control.

The results of factory production control shall be recorded and evaluated in accordance with the provisions of the control plan. The records shall include at least the following information:

- Designation of the product, basic material and components,
- Type of control or testing,
- Date of manufacture of the product and date of testing of the product or basic material and components,
- Result of control and testing and, if appropriate, comparison with requirements,
- Signature of person responsible for factory production control.

The records shall be presented to the approved body involved in the continuous surveillance and shall be presented to Deutsches Institut für Bautechnik on request.

3.2.1.2 Initial type testing

For initial type-testing the results of the tests performed as part of the assessment for the European technical approval may be used unless there are changes in the production line or plant. In such cases the necessary initial type-testing has to be agreed between Deutsches Institut für Bautechnik and the notified body.

²⁰

The "control plan" is a confidential part of the European technical approval and only handed over to the approved body involved in the procedure of attestation of conformity. See section 3.2.2.

3.2.1.3 Other tasks for the manufacturer

The manufacturer shall, on the basis of a contract, involve a body which is approved for the tasks referred to in section 3.1 in the field of screws in order to undertake the actions laid down in section 3.2.2. For this purpose, the control plan referred to in sections 3.2.1.1 and 3.2.2 shall be handed over by the manufacturer to the approved body involved.

The manufacturer shall make a declaration of conformity, stating that the construction product is in conformity with the provisions of the European technical approval ETA-12/0471 issued on 13 June 2013.

3.2.2 Tasks for the approved bodies

The approved body shall perform the

- initial inspection of factory and of factory production control,
- continuous surveillance, assessment and approval of factory production control, in accordance with the provisions laid down in the control plan.

3.2.2.1 Initial inspection of factory and factory production control

The approved body shall ascertain that, in accordance with the control plan, the factory, in particular the staff and equipment, and the factory production control, are suitable to ensure a continuous and orderly manufacturing of the screws with this European technical approval.

3.2.2.2 Continuous surveillance

The approved body shall control the documentation of the factory production control (FPC) twice a year including an annual visit of the factory for routine inspections. It shall be verified that the system of factory production control and the specified manufacturing processes are maintained, taking account of the control plan.

3.2.2.3 Other tasks of the approved body

The approved body shall retain the essential points of its actions referred to above and state the results obtained and conclusions drawn in a written report.

The results of certification and continuous surveillance shall be made available on demand by the certification body to Deutsches Institut für Bautechnik.

The approved certification body involved by the manufacturer shall issue an EC certificate of conformity of the factory production control stating the conformity with the provisions of this European technical approval.

In cases where the provisions of the European technical approval and its control plan are no longer fulfilled the certification body shall withdraw the certificate of conformity and inform Deutsches Institut für Bautechnik without delay.

3.3 CE marking

The CE marking shall be affixed on each packaging of the self-tapping screws. The letters "CE" shall be followed by the identification number of the approved certification body and be accompanied by the following additional information:

- the name and address of the producer (legal entity responsible for the manufacture),
- the last two digits of the year in which the CE marking was affixed,
- the number of the EC certificate for the factory production control,
- the number of the European technical approval,
- name of the product,
- outer thread diameter and length of the self-tapping screws,
- type and mean thickness of the corrosion protection, if relevant.

4 Assumptions under which the fitness of the product for the intended use was favourably assessed

4.1 Manufacturing

BM Quick Drill, BM Quick Drill +, BM Quick Drill II, BM Quick Drill III, BM DT Quick Drill and BM FT Quick Drill self-tapping screws shall be manufactured in accordance with the provisions of this European technical approval using the manufacturing processes as identified at the inspection of the plant by the notified inspection body and laid down in the technical documentation.

The European technical approval is issued for the product on the basis of agreed data/information, deposited with Deutsches Institut für Bautechnik, which identifies the product that has been assessed and judged. Changes to the product or production process, which could result in this deposited data/information being incorrect, shall be notified to Deutsches Institut für Bautechnik before the changes are introduced. Deutsches Institut für Bautechnik will decide whether or not such changes affect the approval and consequently the validity of the CE marking on the basis of the approval and if so whether further assessment or alterations to the approval shall be necessary.

4.2 Installation

The screws are driven into the wood-based member without pre-drilling. The screw holes in steel members shall be pre-drilled with an adequate diameter greater than the outer thread diameter.

BM FT Quick Drill screws with an outer thread diameter of 13 mm or 14 mm and a length greater or equal than 800 mm shall be only driven in a guiding hole with a diameter of 7 mm and a minimum length of 80 mm.

In the case of fastening battens on thermal insulation material on top of rafters the screws shall be driven in the rafter through the battens and the thermal insulation material without pre-drilling in one sequence.

A minimum of two screws shall be used for connections in load bearing timber structures.

The structural solid or glued laminated timber, laminated veneer lumber and similar glued members shall be from spruce, pine or fir.

Countersunk head screws may be used with washers according to Annex 4. After inserting the screw the washers shall touch the surface of the wood-based member completely.

By fastening screws in wood-based members the head of the screws shall be flush with the surface of the wood-based member. For cylinder head screws the head part remains unconsidered.

5 Indications to the manufacturer

5.1 Use, maintenance, repair

The assessment of the fitness for use is based on the assumption that no maintenance is required during the assumed intended working life.

Andreas Kummerow
p. p. Head of Department

beglaubigt:
Dewitt

ANNEX 1 – Characteristic values of the load-carrying capacities

Table 1.1 Characteristic load-carrying capacities of BM Quick Drill, BM Quick Drill +, BM Quick Drill II, BM Quick Drill III, BM DT Quick Drill and BM FT Quick Drill screws

Outer thread diameter [mm]	6.0	8.0	10.0	12.0	13.0	14.0
Characteristic yield moment $M_{y,k}$ [Nm]	10.0	20.0	30.0	42.0	60.0	68.0
Characteristic tensile strength $f_{tens,k}$ [kN]	12.0	21.0	27.0	36.0	55.0	55.0
Characteristic torsional strength $f_{tor,k}$ [Nm]	10.0	24.0	39.0	58.0	95.0	102.0

A.1.1 General

The minimum penetration length of screws in the load-bearing wood-based members shall be $4 \cdot d$.

The inner thread diameter d_1 of the screws shall be greater than the maximal width of the gaps in the layer of the cross-laminated timber.

A.1.2 Laterally loaded screws

The outer thread diameter d shall be used as effective diameter of the screw according to EN 1995-1-1.

A.1.3 Axially loaded screws

The axial slip modulus K_{ser} of the threaded part of a screw for the serviceability limit state per side shall be taken independent of angle α to the grain as:

$$K_{ser} = 780 \cdot d^{0.2} \cdot l_{ef}^{0.4} \quad [\text{N/mm}] \quad (1.1)$$

where

d outer thread diameter of the screw [mm]

l_{ef} penetration length of the screw in the wood-based member [mm].

A.1.3.1 Axial withdrawal capacity

The characteristic withdrawal parameter at an angle of $30^\circ < \alpha \leq 90^\circ$ to the grain based on a characteristic density of the wood-based member of 350 kg/m^3 is

$f_{ax,k} = 11.0 \text{ N/mm}^2$ for screws with $6.0 \text{ mm} \leq d \leq 8.0 \text{ mm}$

$f_{ax,k} = 10.0 \text{ N/mm}^2$ for screws with $d \geq 10.0 \text{ mm}$.

A.1.3.2 Head pull-through capacity

The characteristic value of the head pull-through parameter for BM Quick Drill, BM Quick Drill +, BM Quick Drill II, BM Quick Drill III, BM DT Quick Drill and BM FT Quick Drill screws for a characteristic density of 350 kg/m^3 of the timber and for wood-based panels like

- plywood according to EN 636 and EN 13986
- oriented Strand Board, OSB according to EN 300 and EN 13986
- particleboard according to EN 312 and EN 13986
- fibreboards according to EN 622-2, EN 622-3 and EN 13986
- cement-bonded particle board according to national provisions that apply at the building site
- solid wood panel according to national provisions that apply at the building site

with a thickness of more than 20 mm is

$f_{head,k} = 9.4 \text{ N/mm}^2$ for screws with countersunk and wafer head.

For wood-based panels a maximum characteristic density of 380 kg/m^3 shall be used in equation (8.40b) of EN 1995-1-1.

BM Quick Drill, BM Quick Drill +, BM Quick Drill II, BM Quick Drill III, BM DT Quick Drill and BM FT Quick Drill screws	Annex 1.1
Characteristic values of the load-carrying capacities	

For wood based panels with a thickness between 12 mm and 20 mm the characteristic value of the head pull-through parameter for the screws is:

$$f_{\text{head},k} = 8 \text{ N/mm}^2$$

For wood based panels with a thickness of less than 12 mm the characteristic head pull-through capacity for the screws shall be based on a characteristic value of the head pull-through parameter of 8 N/mm², and limited to 400 N complying with the minimum thickness of the wood based panels of 1.2·d, with d as outer thread diameter and the values in Table 1.2.

Table 1.2 Minimum thickness of wood based panels

Wood based panel	Minimum thickness [mm]
Plywood	6
Fibreboards (hardboards and medium boards)	6
Oriented Strand Boards, OSB	8
Particleboards	8
Cement-bonded particle board	8
Solid wood Panels	12

For BM FT Quick Drill and BM DT Quick Drill screws with countersunk or wafer head the withdrawal capacity of the thread in the wood-based member with the screw head may be taken into account instead of the head pull-through capacity:

$$F_{\text{ax},\alpha,\text{Rk}} = \max \left\{ \begin{array}{l} f_{\text{head},k} \cdot d_h^2 \cdot \left(\frac{\rho_k}{350} \right)^{0,8} \\ \frac{f_{\text{ax},k} \cdot d \cdot l_{\text{ef},k}}{1,2 \cdot \cos^2 \alpha + \sin^2 \alpha} \cdot \left(\frac{\rho_k}{350} \right)^{0,8} \end{array} \right. \quad (1.2)$$

For BM FT Quick Drill and BM DT Quick Drill screws with cylinder head the withdrawal capacity of the thread in the wood-based member with the screw head may be taken into account:

$$F_{\text{ax},\alpha,\text{Rk}} = \frac{f_{\text{ax},k} \cdot d \cdot l_{\text{ef},k}}{1,2 \cdot \cos^2 \alpha + \sin^2 \alpha} \cdot \left(\frac{\rho_k}{350} \right)^{0,8} \quad (1.3)$$

where

- $f_{\text{head},k}$ characteristic value of the head pull-through capacity of the screw [N/mm²]
- $f_{\text{ax},k}$ characteristic value of the axial withdrawal capacity of the threaded part of the screw, $f_{\text{ax},k}$ does not apply for wood-based panels [N/mm²],
- d_h diameter of the screw head [mm],
- ρ_k characteristic density of the wood-based member with the screw head [kg/m³],
- $l_{\text{ef},k}$ penetration length of the threaded part of the screw in the wood-based member with the screw head [mm]
- α angle α between screw axis and grain direction, $30^\circ \leq \alpha \leq 90^\circ$.

In steel-to-timber connections the head pull-through capacity is not governing.

BM Quick Drill, BM Quick Drill +, BM Quick Drill II, BM Quick Drill III, BM DT Quick Drill and BM FT Quick Drill screws	Annex 1.2
Characteristic values of the load-carrying capacities	

A.1.3.3 Compressive capacity of BM FT Quick Drill screws

The design axial capacity $F_{ax,Rd}$ of BM FT Quick Drill screws embedded in timber is the minimum of the axial resistance against pushing-in and the buckling resistance of the screw.

$$F_{ax,Rd} = \min \{ f_{ax,d} \cdot d \cdot l_{ef}; \kappa_c \cdot N_{pl,d} \} \quad (1.4)$$

$f_{ax,d}$ design value of the axial withdrawal capacity of the threaded part of the screw [N/mm²]

d outer thread diameter of the screw [mm]

l_{ef} penetration length of the threaded part of the screw in the timber member [mm]

$$\kappa_c = 1 \quad \text{for } \bar{\lambda}_k \leq 0,2 \quad (1.5)$$

$$\kappa_c = \frac{1}{k + \sqrt{k^2 - \bar{\lambda}_k^2}} \quad \text{for } \bar{\lambda}_k > 0,2 \quad (1.6)$$

$$k = 0,5 \cdot \left[1 + 0,49 \cdot (\bar{\lambda}_k - 0,2) + \bar{\lambda}_k^2 \right] \quad (1.7)$$

and a relative slenderness ratio $\bar{\lambda}_k = \sqrt{\frac{N_{pl,k}}{N_{ki,k}}}$ (1.8)

where:

$N_{pl,k}$ characteristic plastic normal force related to the net cross-section of the inner thread diameter: :

$$N_{pl,k} = \pi \cdot \frac{d_1^2}{4} \cdot f_{y,k} \quad (1.9)$$

$f_{y,k}$ characteristic yield strength, $f_{y,k} = 900 \text{ N/mm}^2$ for BM FT Quick Drill screws with $d \geq 12 \text{ mm}$
 $f_{y,k} = 1.000 \text{ N/mm}^2$ for BM FT Quick Drill screws with $6 \text{ mm} \leq d \leq 10 \text{ mm}$

d_1 inner thread diameter of the screw [mm]

$$N_{pl,d} = \frac{N_{pl,k}}{\gamma_{M1}} \quad (1.10)$$

γ_{M1} partial factor according to EN 1993-1-1 or to the particular national annex

characteristic ideal elastic buckling load:

$$N_{ki,k} = \sqrt{c_h \cdot E_s \cdot I_s} \quad [\text{N}] \quad (1.11)$$

elastic foundation of the screw:

$$c_h = (0.19 + 0.012 \cdot d) \cdot \rho_k \cdot \left(\frac{90^\circ + \alpha}{180^\circ} \right) \quad [\text{N/mm}^2] \quad (1.12)$$

ρ_k characteristic density of the wood-based member [kg/m³]

α angle between screw axis and grain direction, $30^\circ \leq \alpha \leq 90^\circ$

modulus of elasticity:

$$E_s = 210.000 \text{ N/mm}^2$$

second moment of area:

$$I_s = \frac{\pi \cdot d_1^4}{64} \quad [\text{mm}^4] \quad (1.13)$$

BM Quick Drill, BM Quick Drill +, BM Quick Drill II, BM Quick Drill III, BM DT Quick Drill and BM FT Quick Drill screws	Annex 1.3
Characteristic values of the load-carrying capacities	

A.1.4 Spacing, end and edge distances of the screws and minimum thickness of the wood based material

Minimum thickness for structural members is $t = 30$ mm for screws with $d = 6$ mm and $d = 8$ mm, $t = 40$ mm for screws with $d = 10$ mm and $t = 100$ mm for screws with $d \geq 12$ mm.

A.1.4.1 Laterally and/or axially loaded screws

Screws in non pre-drilled holes

For BM screws in non-predrilled holes the minimum spacing and distances are given in EN 1995-1-1:2004+A1:2008, clause 8.3.1.2 and Table 8.2 as for nails in non-predrilled holes. Here, the outer thread diameter d shall be considered.

For Douglas fir members minimum spacing and distances parallel to the grain shall be increased by 50%.

Minimum distances from loaded or unloaded ends shall be $15 \cdot d$ for screws with outer thread diameter $d \geq 8$ mm and timber thickness $t < 5 \cdot d$.

Minimum distances from the unloaded edge perpendicular to the grain may be reduced to $3 \cdot d$ also for timber thickness $t < 5 \cdot d$, if the spacing parallel to the grain and the end distance is at least $25 \cdot d$.

A.1.4.2 Only axially loaded screws

For BM screws the minimum spacings, end and edge distances are given in EN 1995-1-1:2004+A1:2008, clause 8.7.2 and Table 8.6.

A.1.5 Insertion moment

The ratio between the characteristic torsional strength $f_{tor,k}$ and the mean value of insertion moment $R_{tor,mean}$ fulfills the requirement for all screws.

A.1.6 Durability against corrosion

Screws and washers made from carbon steel may have the coatings according to Table 1.3

Table 1.3 Coatings of the BM Quick Drill screws

Coating	Mean thickness of the coating [μm]
electrogalvanised	8

BM Quick Drill, BM Quick Drill +, BM Quick Drill II, BM Quick Drill III, BM DT Quick Drill and BM FT Quick Drill screws	Annex 1.4
Characteristic values of the load-carrying capacities	

ANNEX 2 Compression reinforcement perpendicular to the grain

A.2.1 General

Only BM FT Quick Drill screws shall be used for compression reinforcement perpendicular to the grain. The compression force shall evenly be distributed to the screws used as compression reinforcement. The screws are driven into the timber member perpendicular to the contact surface under an angle between the screw axis and the grain direction of 45° to 90°. The screw heads must be flush with the timber surface. Reinforcing screws for wood-based panels are not covered by this European technical approval.

A.2.2 Design

For the design of reinforced contact areas the following conditions must be met independently of the angle between the screw axis and the grain direction.

The design resistance of a reinforced contact area is:

$$R_{90,d} = \min \left\{ \begin{array}{l} k_{c,90} \cdot B \cdot \ell_{ef,1} \cdot f_{c,90,d} + n \cdot \min \{ R_{ax,d}; \kappa_c \cdot N_{pl,d} \} \\ B \cdot \ell_{ef,2} \cdot f_{c,90,d} \end{array} \right\} \quad (2.1)$$

where:

$k_{c,90}$ Parameter according to EN 1995-1-1:2004+A1: 2008, 6.1.5

B Bearing width [mm]

$\ell_{ef,1}$ Effective contact length according to EN 1995-1-1:2004+A1: 2008, 6.1.5 [mm]

$f_{c,90,d}$ Design compressive strength perpendicular to the grain [N/mm²]

n Number of reinforcing screws, $n = n_0 \cdot n_{90}$

n_0 Number of reinforcing screws arranged in a row parallel to the grain

n_{90} Number of reinforcing screws arranged in a row perpendicular to the grain

$$R_{ax,d} = f_{ax,d} \cdot d \cdot \ell_{ef} \quad [N] \quad (2.2)$$

$f_{ax,d}$ design value of the axial withdrawal capacity of the threaded part of the screw [N/mm²]

d outer thread diameter of the screw [mm]

κ_c according to Annex A.1.3.3

$N_{pl,d}$ according to Annex A.1.3.3 [N]

$\ell_{ef,2}$ Effective contact length in the plane of the screw tips (see Figure 2.1) [mm]

$$\ell_{ef,2} = \{ \ell_{ef} + (n_0 - 1) \cdot a_1 + \min(\ell_{ef}; a_{1,CG}) \} \text{ for end supports (see Figure 2.1 left)}$$

$$\ell_{ef,2} = \{ 2 \cdot \ell_{ef} + (n_0 - 1) \cdot a_1 \} \text{ for intermediate supports (see Figure 2.1 right)}$$

ℓ_{ef} Penetration length of the threaded part of the screw in the timber member [mm]

a_1 Spacing a_1 in a plane parallel to grain, see chapter A.1.4.2 [mm]

$a_{1,CG}$ End distance of the centre of gravity of the threaded part in the timber member, see chapter A.1.4.2 [mm]

BM Quick Drill, BM Quick Drill +, BM Quick Drill II, BM Quick Drill III, BM DT Quick Drill and BM FT Quick Drill screws	Annex 2.1
Compression reinforcement perpendicular to the grain	

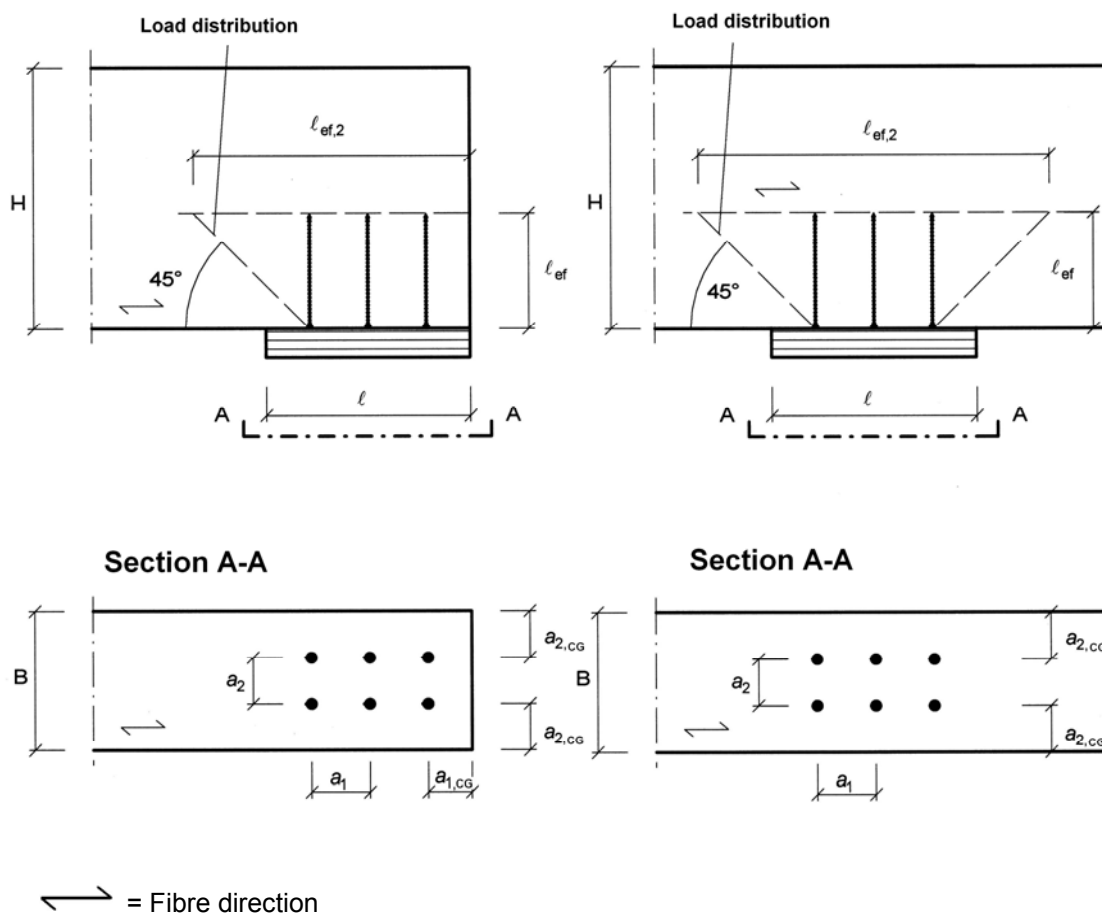

Figure 2.1: Reinforced end support (left) and reinforced intermediate support (right)

<p>BM Quick Drill, BM Quick Drill +, BM Quick Drill II, BM Quick Drill III, BM DT Quick Drill and BM FT Quick Drill screws</p>	
<p>Compression reinforcement perpendicular to the grain</p>	<p>Annex 2.2</p>

ANNEX 3 – Fastening of the thermal insulation material on top of rafters

A.3.1 General

BM Quick Drill, BM Quick Drill +, BM Quick Drill II, BM Quick Drill III, BM DT Quick Drill and BM FT Quick Drill screws may be used for the fixing of thermal insulation material on top of rafters or on wood-based members in vertical façades. In the following, the meaning of the word rafter includes wood-based members with inclinations between 0° and 90°.

The thickness of the thermal insulation material may be up to 300 mm. The thermal insulation material shall be applicable as insulation on top of rafters or on façades according to national provisions that apply at the installation site.

The battens have to be from solid timber (softwood) according to EN 338/ EN 14081-1. The minimum thickness t and the minimum width b of the battens are given in table 3.1:

Table 3.1 Minimum thickness and minimum width of the battens

Outer thread diameter [mm]	Minimum thickness t [mm]	Minimum width b [mm]
6 and 8	30	50
10	40	60
12, 13 and 14	80	100

Instead of battens the wood-based panels specified in chapter A.3.2.1 may be used. Only screws with countersunk head shall be used for fixing wood-based panels on rafters with thermal insulation material as interlayer.

The minimum width of the rafters shall be 60 mm.

The spacing between screws shall be not more than 1.75 m.

Friction forces shall not be considered for the design of the characteristic axial load of the screws.

The anchorage of wind suction forces as well as the bending stresses of the battens shall be considered for design. Screws perpendicular to the grain of the rafter (angle $\alpha = 90^\circ$) may be arranged where required considering the design of the battens.

A.3.2 Parallel inclined screws and thermal insulation material in compression

A.3.2.1 Mechanical model

The system of rafter, thermal insulation material on top of rafter and battens parallel to the rafter may be considered as a beam on elastic foundation. The batten represents the beam, and the thermal insulation material on top of the rafter the elastic foundation. The minimum compression stress of the thermal insulation material at 10 % deformation, measured according to EN 826¹, shall be $\sigma_{(10\%)} = 0,05 \text{ N/mm}^2$. The batten is loaded perpendicular to the axis by point loads F_b . Further point loads F_s are from the shear load of the roof due to dead and snow load, which are transferred from the screw heads into the battens.

Instead of battens the following wood-based panels may be used to cover the thermal insulation material if they are suitable for that use:

- Plywood according to EN 636 and EN 13986,
- Oriented Strand Board, OSB according to EN 300 and EN 13986,
- Particleboard according to EN 312 and EN 13986
- Fibreboards according to EN 622-2, EN 622-3 and EN 13986.

The minimum thickness of the wood-based panels shall be 22 mm.

The word batten includes the meaning of wood-based panels in the following.

¹ EN 826:1996 Thermal insulating products for building applications - Determination of compression behaviour

BM Quick Drill, BM Quick Drill +, BM Quick Drill II, BM Quick Drill III, BM DT Quick Drill and BM FT Quick Drill screws	Annex 3.1
Fastening of the thermal insulation material on top of rafters	

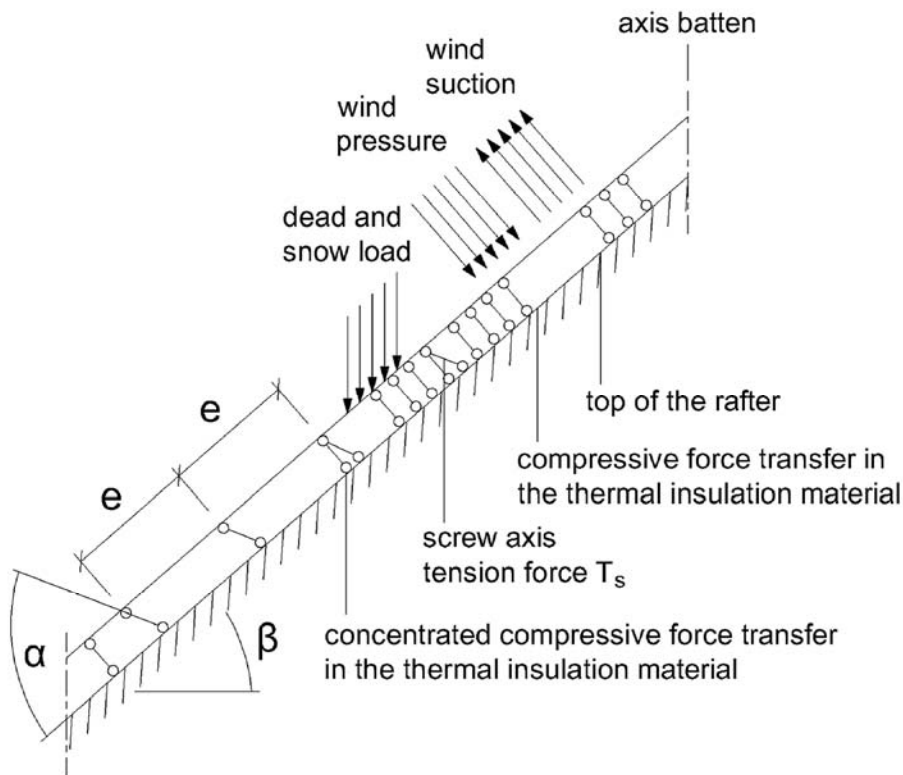
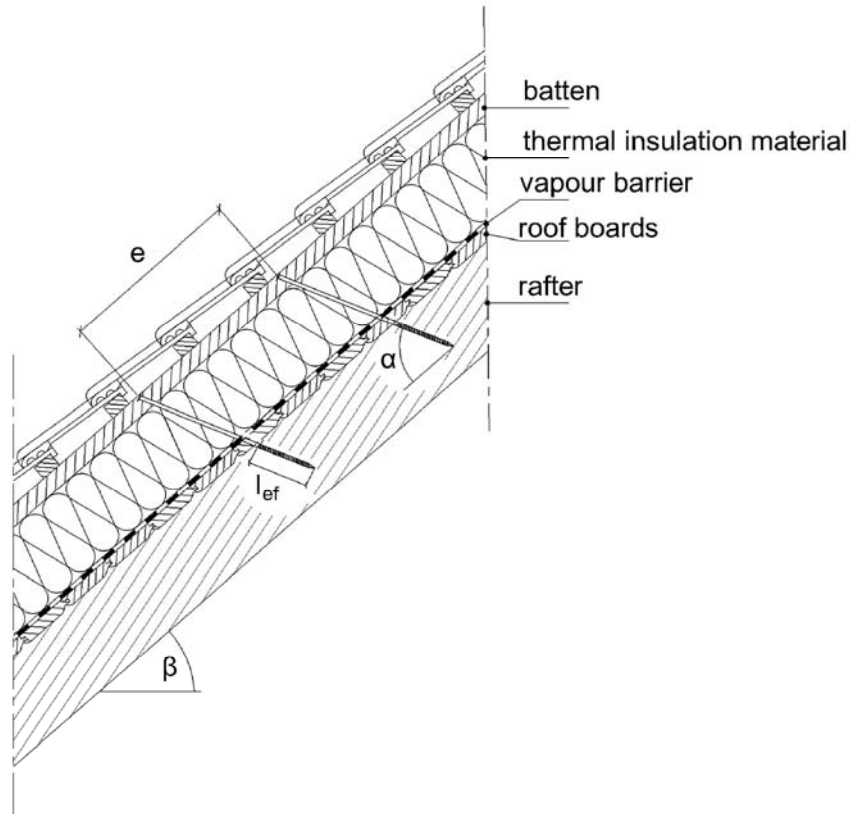

Figure 3.1 Fastening of the thermal insulation material on top of rafters - structural system for parallel inclined screws

BM Quick Drill, BM Quick Drill +, BM Quick Drill II, BM Quick Drill III, BM DT Quick Drill and BM FT Quick Drill screws

Fastening of the thermal insulation material on top of rafters

Annex 3.2

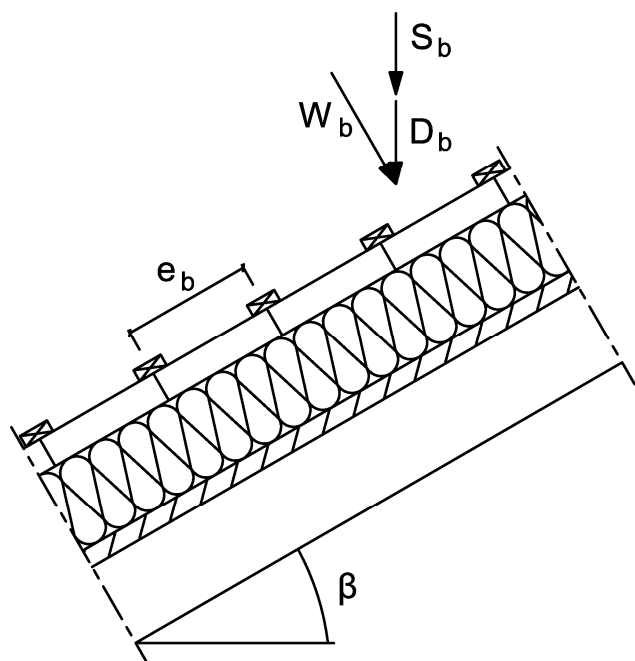

Figure 3.2 Point loads F_b perpendicular to the battens

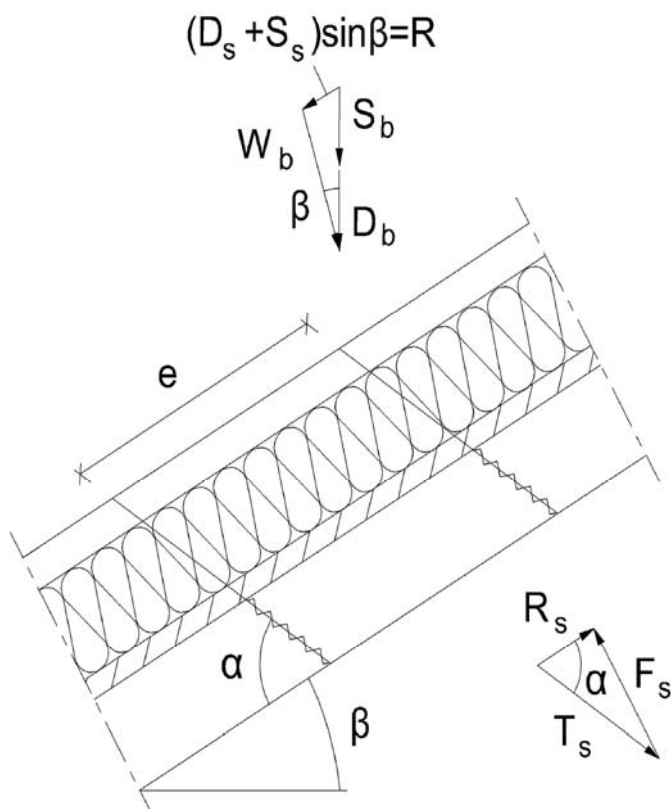

Figure 3.3 Point loads F_s perpendicular to the battens, load application in the area of the screw heads

BM Quick Drill, BM Quick Drill +, BM Quick Drill II, BM Quick Drill III, BM DT Quick Drill
and BM FT Quick Drill screws

Fastening of the thermal insulation material on top of rafters

Annex 3.3

A.3.2.2 Design of the battens

The characteristic value of the bending stresses are calculated as:

$$M_k = \frac{(F_{b,k} + F_{s,k}) \cdot l_{char}}{4} \quad (3.1)$$

where

$$l_{char} = \text{characteristic length } l_{char} = 4 \sqrt{\frac{EI}{w_{ef} \cdot K}} \quad (3.2)$$

EI = bending stiffness of the batten

K = coefficient of subgrade

w_{ef} = effective width of the thermal insulation material

F_{b,k} = characteristic value of the point loads perpendicular to the battens

F_{s,k} = characteristic value of the point loads perpendicular to the battens, load application in the area of the screw heads

The coefficient of subgrade K may be calculated from the modulus of elasticity E_{HI} and the thickness t_{HI} of the thermal insulation material if the effective width w_{ef} of the thermal insulation material under compression is known. Due to the load extension in the thermal insulation material the effective width w_{ef} is greater than the width of the batten or rafter, respectively. For further calculations, the effective width w_{ef} of the thermal insulation material may be determined according to:

$$w_{ef} = w + t_{HI} / 2 \quad (3.3)$$

where

w = minimum from width of the batten or rafter, respectively

t_{HI} = thickness of the thermal insulation material

$$K = \frac{E_{HI}}{t_{HI}} \quad (3.4)$$

The following condition shall be satisfied:

$$\frac{\sigma_{m,d}}{f_{m,d}} = \frac{M_d}{W \cdot f_{m,d}} \leq 1 \quad (3.5)$$

For the calculation of the section modulus W the net cross section shall be considered.

The characteristic value of the shear stresses shall be calculated according to:

$$V_k = \frac{(F_{b,k} + F_{s,k})}{2} \quad (3.6)$$

The following condition need to be satisfied:

$$\frac{\tau_d}{f_{v,d}} = \frac{1.5 \cdot V_d}{A \cdot f_{v,d}} \leq 1 \quad (3.7)$$

For the calculation of the cross section area the net cross section shall be considered.

A.2.2.3 Design of the thermal insulation material

The characteristic value of the compressive stresses in the thermal insulation material shall be calculated according to:

$$\sigma_k = \frac{1.5 \cdot F_{b,k} + F_{s,k}}{2 \cdot l_{char} \cdot w} \quad (3.8)$$

The design value of the compressive stress shall not be greater than 110 % of the compressive stress at 10 % deformation calculated according to EN 826.

BM Quick Drill, BM Quick Drill +, BM Quick Drill II, BM Quick Drill III, BM DT Quick Drill and BM FT Quick Drill screws	Annex 3.4
Fastening of the thermal insulation material on top of rafters	

A.2.2.4 Design of the screws

The screws are loaded predominantly axial. The characteristic value of the axial tension force in the screw may be calculated from the shear loads of the roof R_s :

$$T_{S,k} = \frac{R_{S,k}}{\cos \alpha} \quad (3.9)$$

The load-carrying capacity of axially loaded screws is the minimum design value of the axial withdrawal capacity of the threaded part of the screw, the head pull-through capacity of the screw and the tensile capacity of the screw according to Annex 1.

In order to limit the deformation of the screw head for thermal insulation material with thickness over 220 mm or with compressive strength below 0.12 N/mm², respectively, the axial withdrawal capacity of the screws shall be reduced by the factors k_1 and k_2 :

$$F_{ax,\alpha,Rd} = \min \left\{ \frac{f_{ax,d} \cdot d \cdot l_{ef,r} \cdot k_1 \cdot k_2}{1.2 \cdot \cos^2 \alpha + \sin^2 \alpha} \cdot \left(\frac{\rho_k}{350} \right)^{0.8}; f_{head,d} \cdot d_h^2 \cdot \left(\frac{\rho_k}{350} \right)^{0.8}; \frac{f_{tens,k}}{\gamma_{M2}} \right\} \quad (3.10)$$

where:

$f_{ax,d}$	design value of the axial withdrawal capacity of the threaded part of the screw [N/mm ²]
d	outer thread diameter of the screw [mm]
$l_{ef,r}$	penetration length of the threaded part of the screw in the rafter, $l_{ef} \geq 40$ mm
ρ_k	characteristic density of the wood-based member [kg/m ³]
α	angle α between screw axis and grain direction, $30^\circ \leq \alpha \leq 90^\circ$
$f_{head,d}$	design value of the head pull-through capacity of the screw [N/mm ²]
d_h	head diameter [mm]
$f_{tens,k}$	characteristic tensile capacity of the screw according to Annex 1 [N]
γ_{M2}	partial factor according to EN 1993-1-1 or to the particular national annex
k_1	$\min \{1; 220/t_{HI}\}$
k_2	$\min \{1; \sigma_{10\%}/0,12\}$
t_{HI}	thickness of the thermal insulation material [mm]
$\sigma_{10\%}$	compressive stress of the thermal insulation material under 10 % deformation [N/mm ²]

If equation (3.10) is fulfilled, the deflection of the battens does not need to be considered when designing the load-carrying capacity of the screws.

BM Quick Drill, BM Quick Drill +, BM Quick Drill II, BM Quick Drill III, BM DT Quick Drill and BM FT Quick Drill screws	Annex 3.5
Fastening of the thermal insulation material on top of rafters	

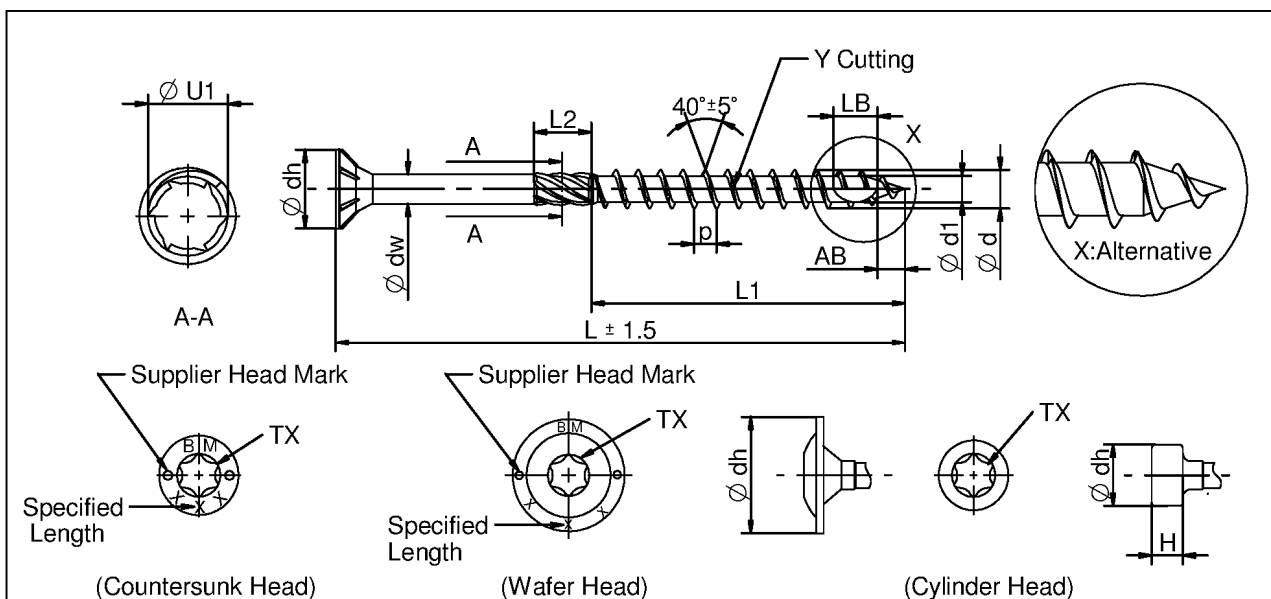

Nominal Diameter	Ø 6.0		Ø 8.0		Ø 10.0		Ø 12.0	
Ødh (Countersunk Head)	Upper Tol.	12.0 +0	15.0 +0	18.5 +0	21.5 +0	Lower Tol.	-1.0	-1.0
Ødh (Wafer Head)	Upper Tol.	15.0 +1.0	22.0 +1.0	25.0 +1.0	29.0 +1.0	Lower Tol.	-1.0	-1.0
Ødh (Cylinder Head)	Upper Tol.	8.0 +0	11.0 +0	13.0 +0	15.0 +0	Lower Tol.	-1.0	-1.0
H (Cylinder Head)	Upper Tol.	5.0 +0.5	6.0 +0.5	7.0 +0.5	8.0 +0.5	Lower Tol.	-0.5	-0.5
Ødw	Upper Tol.	4.25 +0.05	5.8 +0.05	7.0 +0.05	8.0 +0.05	Lower Tol.	-0.05	-0.05
Ød	Upper Tol.	6.0 +0.2	8.0 +0.2	10.0 +0.3	12.0 +0.3	Lower Tol.	-0.2	-0.3
Ød1	Upper Tol.	4.0 +0.2	5.2 +0.25	6.2 +0.3	7.0 +0.3	Lower Tol.	-0.2	-0.3
ØU1	Upper Tol.	5.1 +0.3	7.0 +0.3	8.5 +0.3	8.8 +0.3	Lower Tol.	-0.3	-0.3
LB	Upper Tol.	17.0 +3.0	18.0 +3.0	19.0 +3.0	20.0 +3.0	Lower Tol.	-3.0	-3.0
AB	Upper Tol.	4.0 +2.0	6.0 +2.0	7.0 +2.0	8.0 +2.0	Lower Tol.	-2.0	-2.0
p ±10%	L1 < 180	3.3		5.2	5.6	6.0		
	L1 ≥ 180	4.5						
TX	T30		T40		T50		T50	
L	L1	L2	L1	L2	L1	L2	L1	L2
40 mm	32±1.5		32±1.5					
50 mm	42±1.5		42±1.5					
60~70 mm	52±1.5		52±1.5					
80~120 mm	in 10 mm increments	52±1.5	12±1.5	52±1.5	12±1.5	52±1.5	12±1.5	
130~200 mm	in 10 mm increments	75±1.5	12±1.5	80±1.5	12±1.5	80±1.5	12±1.5	80±1.5 12±1.5
220~300 mm	in 20 mm increments	75±1.5	12±1.5	80±1.5	12±1.5	80±1.5	12±1.5	80±1.5 12±1.5
320~440 mm	in 20 mm increments			80±1.5	12±1.5	80±1.5	12±1.5	80±1.5 12±1.5
460~500 mm	in 20 mm increments			80±1.5	12±1.5	80±1.5	12±1.5	120±1.5 12±1.5
520~600 mm	in 20 mm increments			80±1.5	12±1.5	80±1.5	12±1.5	120±1.5 12±1.5

BM Quick Drill, BM Quick Drill +, BM Quick Drill II, BM Quick Drill III, BM DT Quick Drill and BM FT Quick Drill screws

BM Quick Drill screws

Annex 4.1

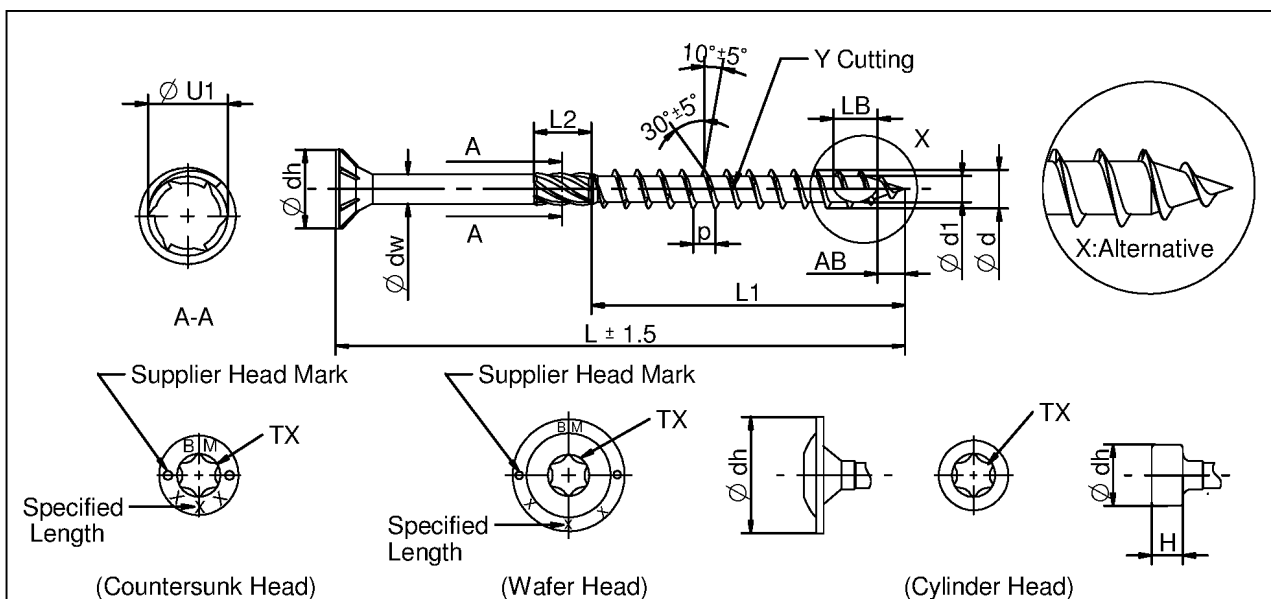

Nominal Diameter	Ø 6.0		Ø 8.0		Ø 10.0		Ø 12.0	
Ødh (Countersunk Head)	Upper Tol.	12.0 +0	15.0 +0	18.5 +0	21.5 +0	Lower Tol.	-1.0	-1.0
Ødh (Wafer Head)	Upper Tol.	15.0 +1.0	22.0 +1.0	25.0 +1.0	29.0 +1.0	Lower Tol.	-1.0	-1.0
Ødh (Cylinder Head)	Upper Tol.	8.0 +0	11.0 +0	13.0 +0	15.0 +0	Lower Tol.	-1.0	-1.0
H (Cylinder Head)	Upper Tol.	5.0 +0.5	6.0 +0.5	7.0 +0.5	8.0 +0.5	Lower Tol.	-0.5	-0.5
Ødw	Upper Tol.	4.25 +0.05	5.8 +0.05	7.0 +0.05	8.0 +0.05	Lower Tol.	-0.05	-0.05
Ød	Upper Tol.	6.0 +0.2	8.0 +0.2	10.0 +0.3	12.0 +0.3	Lower Tol.	-0.2	-0.3
Ød1	Upper Tol.	4.0 +0.2	5.2 +0.25	6.2 +0.3	7.0 +0.3	Lower Tol.	-0.2	-0.3
ØU1	Upper Tol.	5.1 +0.3	7.0 +0.3	8.5 +0.3	8.8 +0.3	Lower Tol.	-0.3	-0.3
LB	Upper Tol.	17.0 +3.0	18.0 +3.0	19.0 +3.0	20.0 +3.0	Lower Tol.	-3.0	-3.0
AB	Upper Tol.	4.0 +2.0	6.0 +2.0	7.0 +2.0	8.0 +2.0	Lower Tol.	-2.0	-2.0
p ±10%	L1 < 180	3.3		5.2	5.6	6.0		
	L1 ≥ 180	4.5						
TX	T30		T40		T50		T50	
L	L1	L2	L1	L2	L1	L2	L1	L2
40 mm	32±1.5		32±1.5					
50 mm	42±1.5		42±1.5					
60~70 mm	52±1.5		52±1.5					
80~120 mm	in 10 mm increments	52±1.5	12±1.5	52±1.5	12±1.5	52±1.5	12±1.5	
130~200 mm	in 10 mm increments	75±1.5	12±1.5	80±1.5	12±1.5	80±1.5	12±1.5	80±1.5 12±1.5
220~300 mm	in 20 mm increments	75±1.5	12±1.5	100±1.5	12±1.5	100±1.5	12±1.5	100±1.5 12±1.5
320~400 mm	in 20 mm increments			100±1.5	12±1.5	100±1.5	12±1.5	100±1.5 12±1.5
420~500 mm	in 20 mm increments			100±1.5	12±1.5	100±1.5	12±1.5	120±1.5 12±1.5
520~600 mm	in 20 mm increments			100±1.5	12±1.5	100±1.5	12±1.5	120±1.5 12±1.5

BM Quick Drill, BM Quick Drill +, BM Quick Drill II, BM Quick Drill III, BM DT Quick Drill and BM FT Quick Drill screws

BM Quick Drill + screws

Annex 4.2

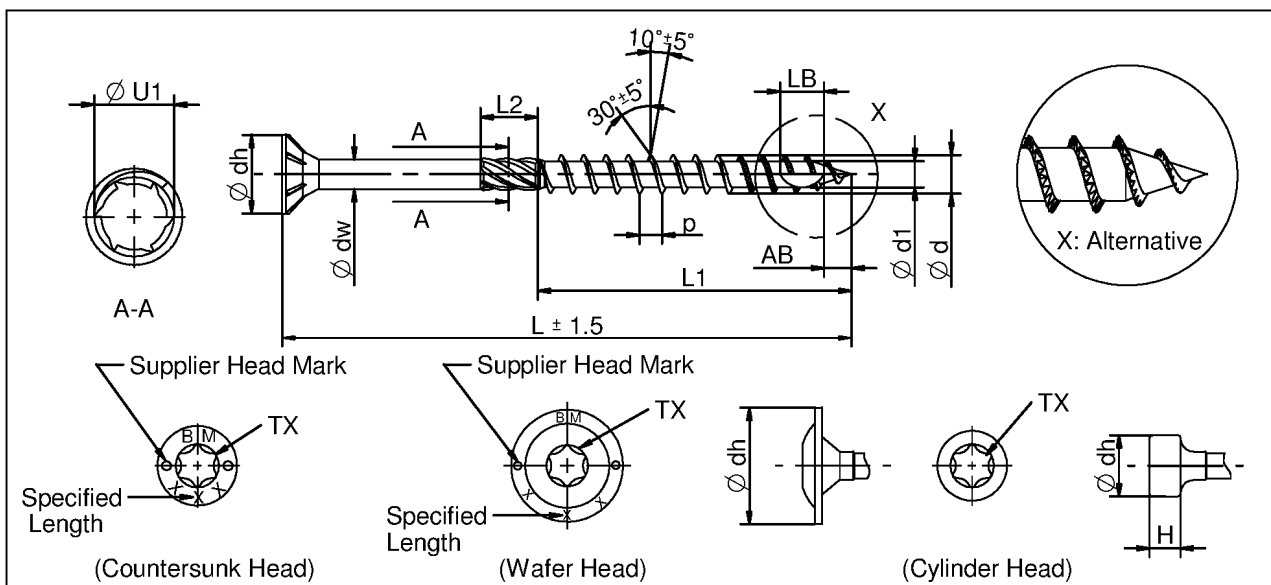

Nominal Diameter	Ø 6.0		Ø 8.0		Ø 10.0	
Ødh (Countersunk Head)	Upper Tol.	12.0 +0	15.0 +0	18.5 +0	Lower Tol.	-1.0
Ødh (Wafer Head)	Upper Tol.	15.0 +1.0	22.0 +1.0	25.0 +1.0	Lower Tol.	-1.0
Ødh (Cylinder Head)	Upper Tol.	8.0 +0	11.0 +0	13.0 +0	Lower Tol.	-1.0
H (Cylinder Head)	Upper Tol.	5.0 +0.5	6.0 +0.5	7.0 +0.5	Lower Tol.	-0.5
Ødw	Upper Tol.	4.25 +0.05	5.8 +0.05	7.0 +0.05	Lower Tol.	-0.05
Ød	Upper Tol.	6.0 +0.2	8.0 +0.2	10.0 +0.3	Lower Tol.	-0.2
Ød1	Upper Tol.	4.0 +0.2	5.2 +0.25	6.2 +0.3	Lower Tol.	-0.2
ØU1	Upper Tol.	5.1 +0.3	7.0 +0.3	8.5 +0.3	Lower Tol.	-0.3
LB	Upper Tol.	17.0 +3.0	18.0 +3.0	19.0 +3.0	Lower Tol.	-3.0
AB	Upper Tol.	4.0 +2.0	6.0 +2.0	7.0 +2.0	Lower Tol.	-2.0
p ±10%	L1 < 180	3.3	5.2		5.6	
	L1 > 180	4.5				
TX	T30		T40		T50	
L	L1	L2	L1	L2	L1	L2
40 mm	32±1.5		32±1.5			
50 mm	42±1.5		42±1.5			
60~70 mm	52±1.5		52±1.5			
80~120 mm	52±1.5	12±1.5	52±1.5	12±1.5	52±1.5	12±1.5
130~200 mm	75±1.5	12±1.5	80±1.5	12±1.5	80±1.5	12±1.5
220~300 mm	75±1.5	12±1.5	80±1.5	12±1.5	80±1.5	12±1.5
320~400 mm			80±1.5	12±1.5	80±1.5	12±1.5
420~500 mm			80±1.5	12±1.5	80±1.5	12±1.5
520~600 mm			80±1.5	12±1.5	80±1.5	12±1.5

BM Quick Drill, BM Quick Drill +, BM Quick Drill II, BM Quick Drill III, BM DT Quick Drill and BM FT Quick Drill screws

BM Quick Drill II screws

Annex 4.3

English translation prepared by DIBt

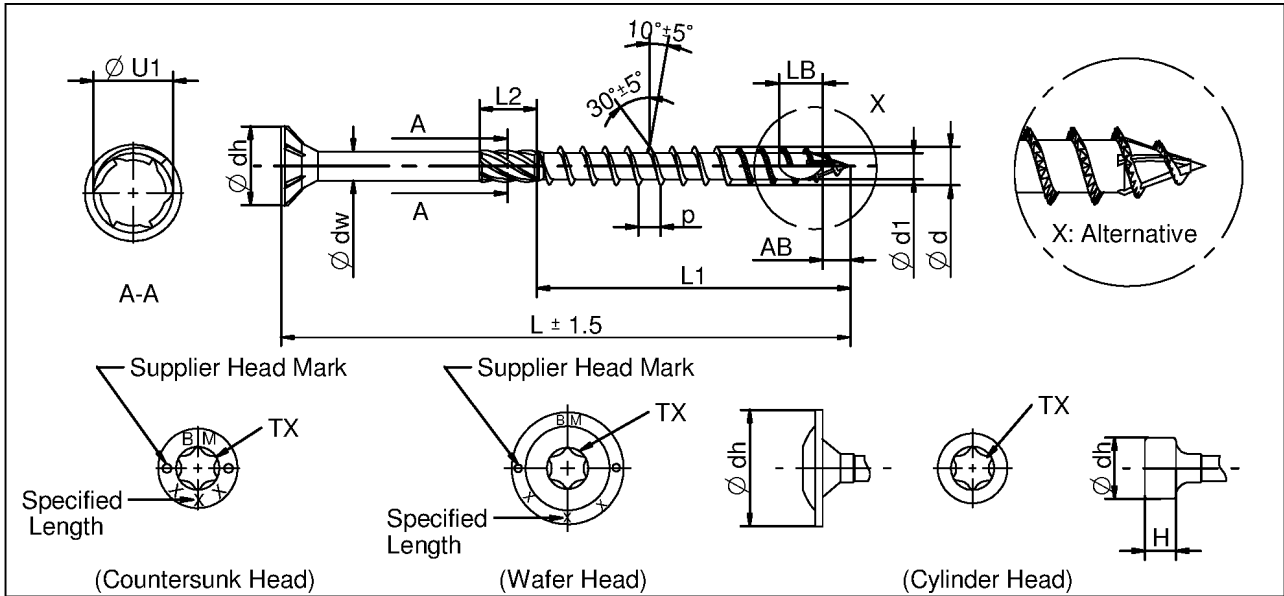

Nominal Diameter	Ø 6.0		Ø 8.0		Ø 10.0		Ø 12.0	
Ødh (Countersunk Head)	Upper Tol.	12.0 +0	15.0 +0	18.5 +0	21.5 +0	Lower Tol.	-1.0	-1.0
Ødh (Wafer Head)	Upper Tol.	15.0 +1.0	22.0 +1.0	25.0 +1.0	29.0 +1.0	Lower Tol.	-1.0	-1.0
Ødh (Cylinder Head)	Upper Tol.	8.0 +0	11.0 +0	13.0 +0	15.0 +0	Lower Tol.	-1.0	-1.0
H (Cylinder Head)	Upper Tol.	5.0 +0.5	6.0 +0.5	7.0 +0.5	8.0 +0.5	Lower Tol.	-0.5	-0.5
Ødw	Upper Tol.	4.25 +0.05	5.8 +0.05	7.0 +0.05	8.0 +0.05	Lower Tol.	-0.05	-0.05
Ød	Upper Tol.	6.0 +0.2	8.0 +0.2	10.0 +0.3	12.0 +0.3	Lower Tol.	-0.2	-0.3
Ød1	Upper Tol.	4.0 +0.2	5.2 +0.25	6.2 +0.3	7.0 +0.3	Lower Tol.	-0.2	-0.3
ØU1	Upper Tol.	5.1 +0.3	7.0 +0.3	8.5 +0.3	8.8 +0.3	Lower Tol.	-0.3	-0.3
LB	Upper Tol.	17.0 +3.0	18.0 +3.0	19.0 +3.0	20.0 +3.0	Lower Tol.	-3.0	-3.0
AB	Upper Tol.	4.0 +2.0	6.0 +2.0	7.0 +2.0	8.0 +2.0	Lower Tol.	-2.0	-2.0
p ±10%	L1 < 180	3.3		5.2	5.6	6.0		
	L1 ≥ 180	4.5						
TX	T30		T40		T50		T50	
L	L1	L2	L1	L2	L1	L2	L1	L2
40 mm	32±1.5		32±1.5					
50 mm	42±1.5		42±1.5					
60 ~ 70 mm	52±1.5		52±1.5					
80~120 mm	in 10 mm increments	52±1.5	12±1.5	52±1.5	12±1.5	52±1.5	12±1.5	
130~200 mm	in 10 mm increments	75±1.5	12±1.5	80±1.5	12±1.5	80±1.5	12±1.5	80±1.5 12±1.5
220~300 mm	in 20 mm increments	75±1.5	12±1.5	100±1.5	12±1.5	100±1.5	12±1.5	100±1.5 12±1.5
320~400 mm	in 20 mm increments			100±1.5	12±1.5	100±1.5	12±1.5	100±1.5 12±1.5
420~500 mm	in 20 mm increments			100±1.5	12±1.5	100±1.5	12±1.5	120±1.5 12±1.5
520~600 mm	in 20 mm increments			100±1.5	12±1.5	100±1.5	12±1.5	120±1.5 12±1.5

BM Quick Drill, BM Quick Drill +, BM Quick Drill II, BM Quick Drill III, BM DT Quick Drill and BM FT Quick Drill screws

BM Quick Drill III screws

Annex 4.4

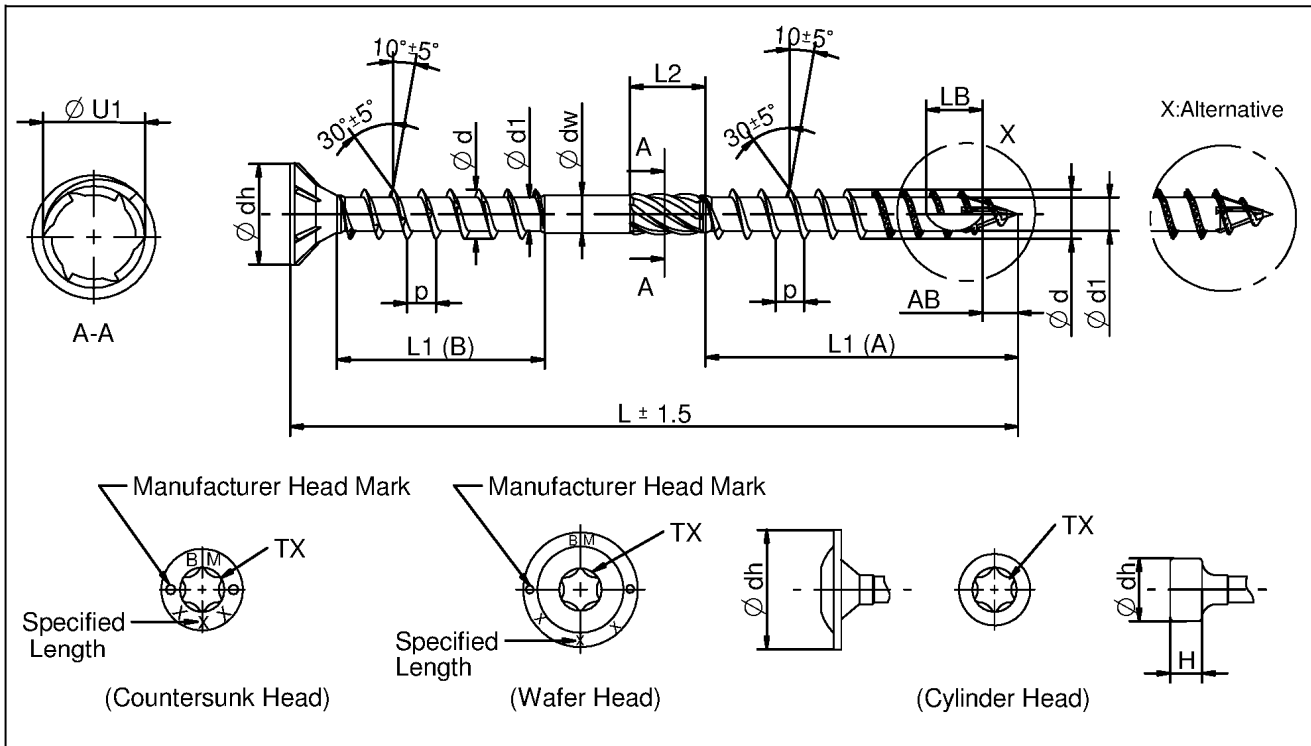

Nominal Diameter	$\varnothing 6.0$			$\varnothing 8.0$			$\varnothing 10.0$		
$\varnothing dh$ (Countersunk Head)	Upper Tol.	12.0	+0	15.0	+0	18.5	+0	25.0	+0
	Lower Tol.		-1.0		-1.0		-1.0		-1.0
$\varnothing dh$ (Wafer Head)	Upper Tol.	15.0	+1.0	22.0	+1.0	25.0	+1.0	25.0	+1.0
	Lower Tol.		-1.0		-1.0		-1.0		-1.0
$\varnothing dh$ (Cylinder Head)	Upper Tol.	8.0	+0	11.0	+0	13.0	+0	13.0	+0
	Lower Tol.		-1.0		-1.0		-1.0		-1.0
H (Cylinder Head)	Upper Tol.	5.0	+0.5	6.0	+0.5	7.0	+0.5	7.0	+0.5
	Lower Tol.		-0.5		-0.5		-0.5		-0.5
$\varnothing dw$	Upper Tol.	4.25	+0.05	5.8	+0.05	7.0	+0.05	7.0	+0.05
	Lower Tol.		-0.05		-0.05		-0.05		-0.05
$\varnothing d$	Upper Tol.	6.0	+0.2	8.0	+0.2	10.0	+0.3	10.0	+0.3
	Lower Tol.		-0.2		-0.2		-0.3		-0.3
$\varnothing d1$	Upper Tol.	4.0	+0.2	5.2	+0.25	6.2	+0.3	6.2	+0.3
	Lower Tol.		-0.2		-0.25		-0.3		-0.3
$\varnothing U1$	Upper Tol.	5.1	+0.3	7.0	+0.3	8.5	+0.3	8.5	+0.3
	Lower Tol.		-0.3		-0.3		-0.3		-0.3
LB	Upper Tol.	17.0	+3.0	18.0	+3.0	19.0	+3.0	19.0	+3.0
	Lower Tol.		-3.0		-3.0		-3.0		-3.0
AB	Upper Tol.	4.0	+0.2	6.0	+0.2	7.0	+0.2	7.0	+0.2
	Lower Tol.		-0.2		-0.2		-0.2		-0.2
$p \pm 10\%$	$L1 < 180$		3.3	5.2			5.6		
	$L1 \geq 180$		4.5	T40			T50		
TX	T30			T40			T50		
L	L1 (A)	L1 (B)	L2	L1 (A)	L1 (B)	L2	L1 (A)	L1 (B)	L2
165~200 mm	75 ± 1.5	60 ± 1.5	12 ± 1.5	80 ± 1.5	60 ± 1.5	12 ± 1.5	80 ± 1.5	60 ± 1.5	12 ± 1.5
201~300 mm	75 ± 1.5	60 ± 1.5	12 ± 1.5	100 ± 1.5	60 ± 1.5	12 ± 1.5	100 ± 1.5	60 ± 1.5	12 ± 1.5
301~400 mm				100 ± 1.5	60 ± 1.5	12 ± 1.5	100 ± 1.5	60 ± 1.5	12 ± 1.5
401~500 mm				100 ± 1.5	60 ± 1.5	12 ± 1.5	100 ± 1.5	60 ± 1.5	12 ± 1.5
501~600 mm							100 ± 1.5	60 ± 1.5	12 ± 1.5

BM Quick Drill, BM Quick Drill +, BM Quick Drill II, BM Quick Drill III, BM DT Quick Drill and BM FT Quick Drill screws

BM Quick Drill DT screws

Annex 4.5

English translation prepared by DIBt

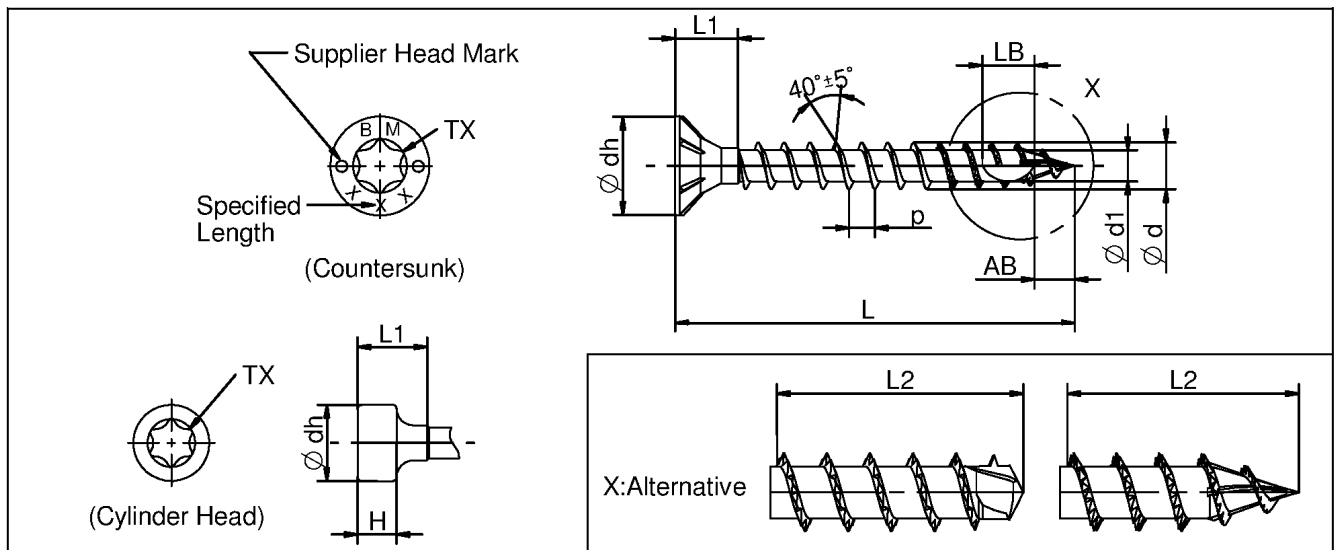

Nominal Diameter	Ø 6.0	Ø 8.0	Ø 10.0	Ø 12.0	Ø 13.0	Ø 14.0
Ødh (Countersunk Head)	Upper Tol. 12.0 +0 Lower Tol. -1.0	Upper Tol. 15.0 +0 Lower Tol. -1.0	Upper Tol. 18.5 +0 Lower Tol. -1.0	Upper Tol. 21.5 +0 Lower Tol. -1.0	Upper Tol. 22.0 +0 Lower Tol. -1.0	Upper Tol. 22.5 +0 Lower Tol. -1.0
Ødh (Cylinder Head)	Upper Tol. 8.0 +0 Lower Tol. -1.0	Upper Tol. 11.0 +0 Lower Tol. -1.0	Upper Tol. 13.0 +0 Lower Tol. -1.0	Upper Tol. 15.0 +0 Lower Tol. -1.0	Upper Tol. 15.0 +0 Lower Tol. -1.0	Upper Tol. 15.0 +0 Lower Tol. -1.0
H (Cylinder Head)	Upper Tol. 5.0 +0.5 Lower Tol. -0.5	Upper Tol. 6.0 +0.5 Lower Tol. -0.5	Upper Tol. 7.0 +0.5 Lower Tol. -0.5	Upper Tol. 8.0 +0.5 Lower Tol. -0.5	Upper Tol. 9.0 +0.5 Lower Tol. -0.5	Upper Tol. 10.0 +0.5 Lower Tol. -0.5
Ød	Upper Tol. 6.0 +0.2 Lower Tol. -0.2	Upper Tol. 8.0 +0.2 Lower Tol. -0.2	Upper Tol. 10.0 +0.2 Lower Tol. -0.2	Upper Tol. 12.0 +0.2 Lower Tol. -0.2	Upper Tol. 13.0 +0.2 Lower Tol. -0.2	Upper Tol. 14.0 +0.2 Lower Tol. -0.2
Ød1	Upper Tol. 4.0 +0.2 Lower Tol. -0.2	Upper Tol. 5.2 +0.25 Lower Tol. -0.25	Upper Tol. 6.2 +0.3 Lower Tol. -0.3	Upper Tol. 7.0 +0.3 Lower Tol. -0.3	Upper Tol. 8.0 +0.3 Lower Tol. -0.3	Upper Tol. 8.5 +0.3 Lower Tol. -0.3
LB	Upper Tol. 17.0 +3.0 Lower Tol. -3.0	Upper Tol. 18.0 +3.0 Lower Tol. -3.0	Upper Tol. 19.0 +3.0 Lower Tol. -3.0	Upper Tol. 20.0 +3.0 Lower Tol. -3.0	Upper Tol. 21.0 +3.0 Lower Tol. -3.0	Upper Tol. 22.0 +3.0 Lower Tol. -3.0
AB	Upper Tol. 4.0 +2.0 Lower Tol. -2.0	Upper Tol. 6.0 +2.0 Lower Tol. -2.0	Upper Tol. 7.0 +2.0 Lower Tol. -2.0	Upper Tol. 8.0 +2.0 Lower Tol. -2.0	Upper Tol. 8.5 +2.0 Lower Tol. -2.0	Upper Tol. 9.0 +2.0 Lower Tol. -2.0
p ±10%	3.8	4.8	5.6	6.0	6.0	6.8
TX	T30	T40	T50	T50	T50	T50
L	L1	L1	L1	L1	L1	L1
100~190 mm(±1.5) in 10 mm increments	max.12mm	max.19mm	max.20mm			
200~290 mm(±1.5) in 10 mm increments	max.12mm	max.19mm	max.20mm	max.20.5mm	max.21mm	max.22mm
300~390 mm(±1.5) in 10 mm increments		max.19mm	max.20mm	max.20.5mm	max.21mm	max.22mm
400~490 mm(±1.5) in 10 mm increments		max.19mm	max.20mm	max.20.5mm	max.21mm	max.22mm
500~590 mm(±1.5) in 10 mm increments			max.20mm	max.20.5mm	max.21mm	max.22mm
600~790 mm(±1.5) in 10 mm increments				max.20.5mm	max.21mm	max.22mm
800~990 mm(±1.5) in 10 mm increments				max.20.5mm	max.21mm	max.22mm
1000~1190 mm(±1.5) in 10 mm increments					max.21mm	max.22mm
1200~1500 mm(±1.5) in 10 mm increments						max.22mm

BM Quick Drill, BM Quick Drill +, BM Quick Drill II, BM Quick Drill III, BM DT Quick Drill and BM FT Quick Drill screws

BM Quick Drill FT screws

Annex 4.6

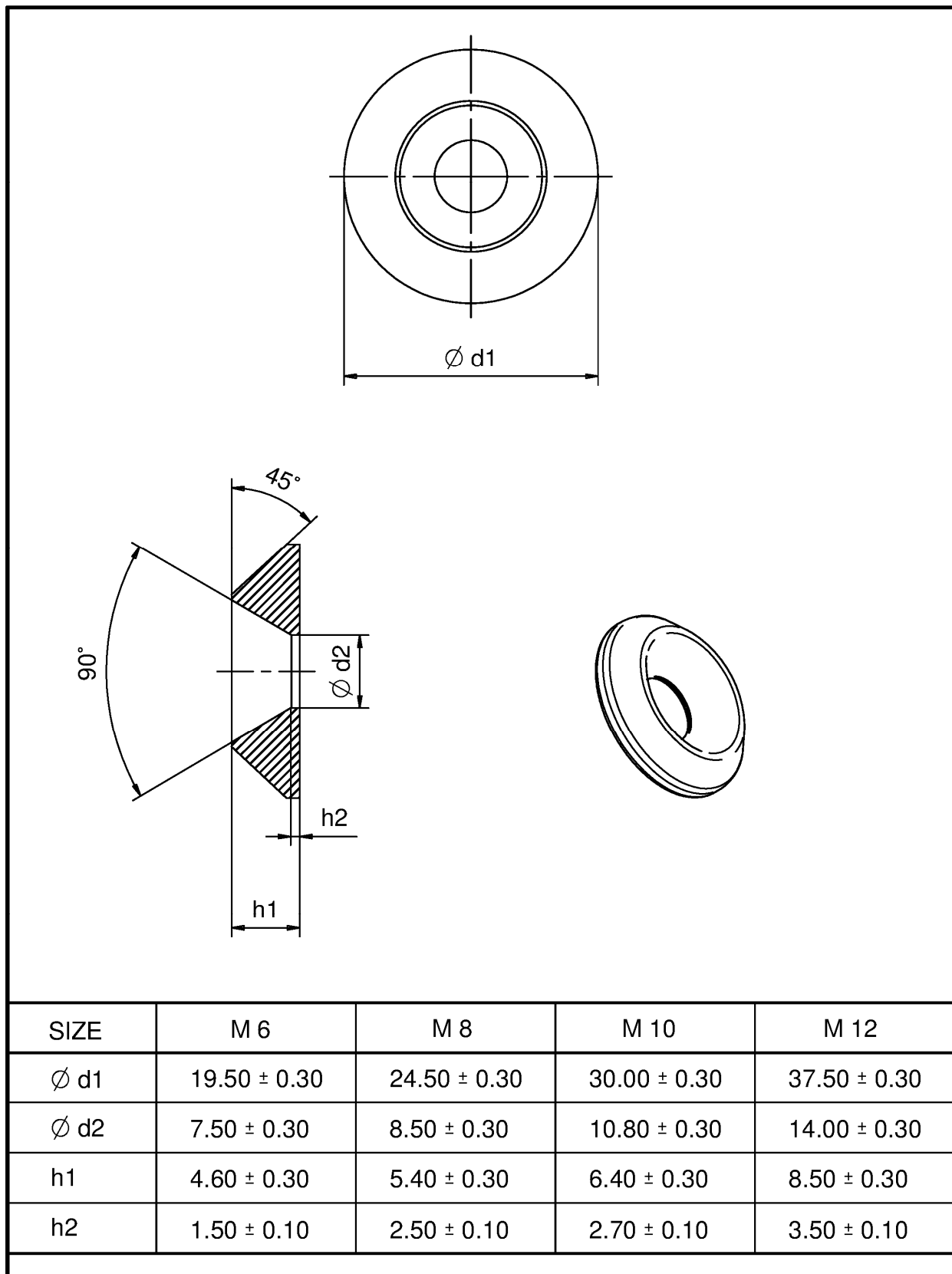

BM Quick Drill, BM Quick Drill +, BM Quick Drill II, BM Quick Drill III, BM DT Quick Drill
and BM FT Quick Drill screws

Washer

Annex 4.7